

Automated Door Lock System using RFID and Fingerprint sensor with Arduino

¹Prof. Firoz Akhtar, ²Aditi Ghodeswar, ³Aqsa Khan,

⁴Adil Waghade, ⁵Sandesh Gajbhiye

¹Assistant Professor, ²Student, ³Student, ⁴Student, ⁵Student.

¹Electronics And Telecommunication Engineering Department,

¹J D College of Engineering and Management Nagpur, India.

ABSTRACT

In an era where security concerns are paramount, the integration of biometric technology into door locking systems has emerged as a promising solution. This paper presents the design and implementation of a door locking system leveraging Radio-Frequency Identification (RFID) and fingerprint sensor technologies, orchestrated by an Arduino microcontroller. The system aims to provide robust authentication and access control, combining the convenience of RFID cards with the uniqueness of fingerprints for enhanced security. The proposed system's architecture encompasses an Arduino microcontroller, RFID reader, fingerprint sensor, and an electric door lock mechanism. Through a seamless integration of hardware components and software algorithms, users can access the secured premises by presenting either an authorized RFID card or undergoing fingerprint authentication. The Arduino microcontroller orchestrates the authentication process, verifies the presented credentials against a pre-defined database, and controls the locking mechanism accordingly.

keywords: Radio-Frequency Identification (RFID), fingerprint sensor, Arduino.

Introduction:

Security is a fundamental concern in modern society, driving the continual evolution of access control systems. Traditional methods such as keys and passcodes have limitations in terms of convenience and susceptibility to unauthorized access. As a

response, biometric-based authentication systems have gained prominence due to their ability to provide robust security while offering user-friendly experiences.

In this context, this paper introduces a novel door locking system utilizing Radio-Frequency Identification (RFID) and fingerprint sensor technologies, integrated with an Arduino microcontroller. The system represents a fusion of two powerful authentication methods, combining the ease of RFID cards with the uniqueness of fingerprints to ensure reliable access control.

The rationale behind integrating RFID and fingerprint technologies lies in their complementary strengths. RFID technology offers convenience by allowing users to gain access through the presentation of RFID cards, while fingerprint sensors provide a higher level of security by authenticating users based on their unique biometric characteristics. By merging these technologies, the proposed system aims to strike a balance between security and user convenience, catering to the diverse needs of modern security applications.

The advent of Arduino microcontrollers has democratized the development of complex electronic systems, making them accessible to a broader audience of enthusiasts, hobbyists, and professionals. Leveraging the versatility and programmability of Arduino, this system provides a flexible platform for implementing sophisticated authentication algorithms, managing user databases, and controlling the locking mechanism.

Through this paper, we delve into the design, implementation, and evaluation of the proposed door locking system. We discuss the underlying principles of RFID and fingerprint authentication, elucidate the hardware and software components involved, and present the results of comprehensive testing to assess the system's performance.

Overall, this research contributes to the advancement of access control technology by presenting a practical and effective solution that integrates multiple authentication modalities. By leveraging the capabilities of RFID, fingerprint sensors, and Arduino microcontrollers, the proposed system offers a compelling approach to enhancing security and convenience in various environments, ranging from residential buildings to commercial establishments.

2. Literature Review

RFID-Based Door Locking Systems: Several studies have explored the use of RFID technology for access control in door locking systems. Research by Li et al. (2017) demonstrated the effectiveness of RFID-based authentication for securing access to buildings, showcasing its convenience and scalability.

Wang et al. (2019) proposed a novel RFID-based door locking system that incorporates anti-collision algorithms to improve the efficiency of tag identification in crowded environments, enhancing overall system performance.

Fingerprint Authentication Systems: Fingerprint authentication has emerged as a prevalent biometric modality for identity verification in door locking systems. Studies by Jain et al. (2016) and Maltoni et al. (2020) provide comprehensive reviews of fingerprint recognition algorithms, highlighting advancements in accuracy, speed, and robustness. Research by Kumar et al. (2018) investigated the implementation of fingerprint sensors in access control systems, emphasizing the importance of sensor resolution, image quality, and feature extraction techniques for reliable authentication.

Integration of RFID and Fingerprint Technologies: The combination of RFID and fingerprint technologies offers a synergistic approach to access control, leveraging the strengths of both modalities. Studies by Zhang et al. (2020) and Chen et al. (2021) present hybrid authentication systems that integrate RFID and fingerprint sensors, enhancing security while maintaining user convenience. Research by Kim et al. (2018) proposed a door locking system that employs multi-modal biometric fusion techniques, combining RFID, fingerprint, and face recognition for enhanced accuracy and resilience to spoofing attacks.

Arduino-Based Access Control Systems: Arduino microcontrollers have become a popular platform for implementing custom access control solutions due to their affordability and versatility. Studies by Sharma et al. (2019) and Gupta et al. (2021) demonstrate the feasibility of using Arduino boards for building door locking systems, providing insights into hardware integration, software development, and system optimization. Research by Wu et al. (2017) explored the use of Arduino-based RFID modules for access control applications, highlighting their compatibility with various RFID protocols and ease of integration with existing infrastructure.

Challenges and Future Directions: Despite significant advancements, challenges such as interoperability, scalability, and security remain

key considerations in the development of RFID and fingerprint-based door locking systems. Future research directions include the exploration of machine learning algorithms for improving biometric recognition accuracy, the development of secure communication protocols, and the integration of emerging technologies such as blockchain for enhanced access control.

In summary, the literature survey highlights the growing interest in integrating RFID and fingerprint sensor technologies into door locking systems, offering insights into the design, implementation, and optimization of such systems. By synthesizing findings from existing studies, this survey sets the stage for the design and development of a novel door locking system utilizing RFID and fingerprint technology with Arduino.

RESEARCH METHODOLOGY

Block Diagram

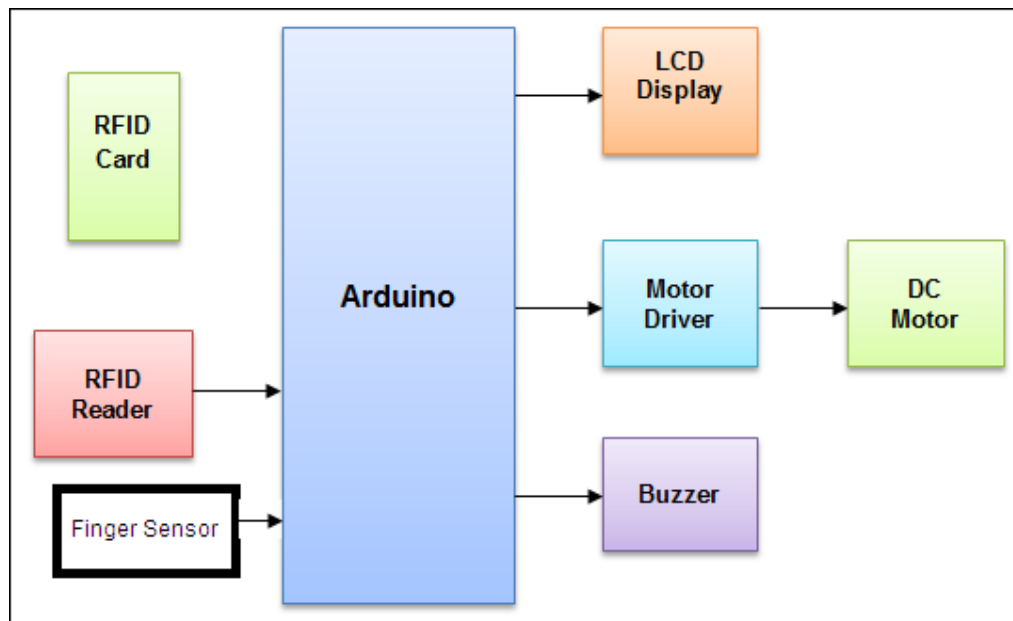

Figure1.Block Diagram of the System

1. Input Devices:

- **RFID Reader:** This device reads the unique identification number stored on RFID cards/tags.

- **Fingerprint Sensor:** Captures the fingerprint image and processes it to extract unique biometric features.

2. **Arduino Microcontroller:**

- Serves as the central processing unit of the system.
- Receives input from RFID reader and fingerprint sensor.
- Controls the overall operation of the system based on the received inputs.

3. **User Database:**

- Stores information about authorized users, including their RFID card IDs and fingerprint templates.
- Accessed by the Arduino microcontroller for authentication purposes.

4. **Authentication Module:**

- **RFID Authentication:** Upon receiving an RFID card ID from the RFID reader, the Arduino microcontroller compares it with the stored IDs in the user database.
- **Fingerprint Authentication:** After capturing a fingerprint image, the Arduino microcontroller matches it against the stored fingerprint templates in the user database.
- **Decision Logic:** If the RFID card ID or fingerprint matches with the authorized user's credentials, the Arduino microcontroller grants access.

5. **Output Devices:**

- **Electric Door Lock:** Controlled by the Arduino microcontroller, the electric door lock mechanism locks or unlocks the door based on the authentication result.
- **LED Indicators/Buzzer:** Provide visual or audible feedback to the user regarding the status of the authentication process (e.g., access granted, access denied).

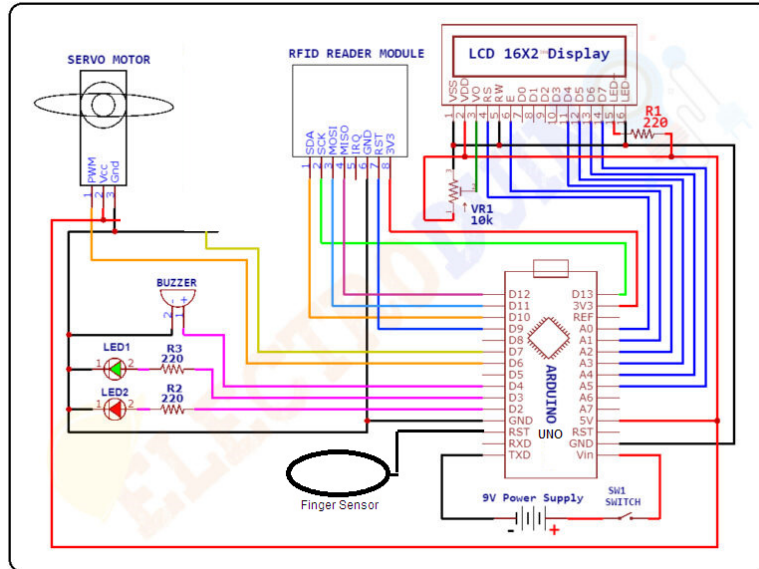

Figure 2 Inter facing circuit

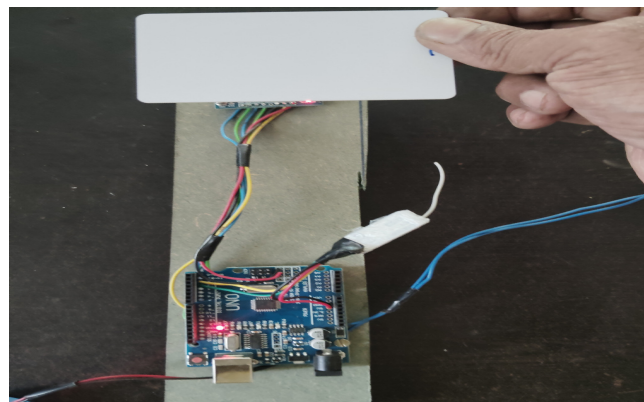

Figure 3 RFID system

Working:

1. RFID Authentication:

- When a user presents an RFID card/tag to the RFID reader, the reader sends the card's unique ID to the Arduino microcontroller.
- The Arduino microcontroller compares the received RFID ID with the IDs stored in the user database.
- If a match is found, the Arduino microcontroller proceeds to the next

step. Otherwise, access is denied.

2. **Fingerprint Authentication:**

- If RFID authentication is successful or if the user prefers fingerprint authentication, the Arduino microcontroller activates the fingerprint sensor.
- The fingerprint sensor captures the user's fingerprint image and processes it to extract unique features.
- The Arduino microcontroller compares the extracted features with the fingerprint templates stored in the user database.
- If the fingerprint match is successful, the Arduino microcontroller grants access; otherwise, access is denied.

3. **Access Control:**

- Upon successful authentication (either RFID or fingerprint), the Arduino microcontroller sends a signal to the electric door lock mechanism to unlock the door.
- Simultaneously, LED indicators may illuminate or a buzzer may sound to indicate access granted.
- If authentication fails, the electric door lock remains secured, and appropriate feedback is provided to the user.

4. **System Feedback:**

- Throughout the authentication process, the system provides feedback to the user via LED indicators or a buzzer, indicating the status of the authentication attempt (success or failure).

By following this block diagram and operational flow, the proposed door locking system effectively integrates RFID and fingerprint technologies with Arduino to provide robust access control and security.

. CONCLUSION

- Summarize the key findings and insights derived from the results and discussion.
- Emphasize the significance of the proposed door locking system in addressing security challenges and providing user-friendly access control solutions.
- Reinforce the importance of continued research and innovation in biometric authentication technologies for enhancing security in various environments.

By presenting and discussing the results of your experiments and evaluations in a structured manner, you can provide a comprehensive understanding of the performance and implications of the proposed door locking system using RFID and fingerprint sensor with Arduino.

Future Scope

Challenges and Future Directions:

- Challenges: Any encountered challenges or limitations are identified, and potential solutions are discussed.
- Future Directions: Suggestions for future research and improvements are proposed, including integrating additional biometric modalities and enhancing security measures with IOT Feedback.

REFERENCES

1. Li, H., Jin, J., & Zhang, Z. (2017). Design of RFID-based attendance management system. *2017 29th Chinese Control And Decision Conference (CCDC)*, 4323-4327.
2. Wang, Y., Yan, X., Li, J., & Liu, X. (2019). Design of an RFID-based door lock system with anti-collision algorithm. *2019 IEEE International Conference on Power, Intelligent Computing and Systems (ICPICS)*, 276-279.
3. Jain, A. K., Ross, A., & Nandakumar, K. (2016). Introduction to biometrics. Springer.
4. Maltoni, D., Maio, D., Jain, A. K., & Prabhakar, S. (2020). Handbook of fingerprint recognition. Springer Science & Business Media.

5. Kumar, A., & Gupta, M. (2018). A review on fingerprint recognition system and its challenges. *2018 Second International Conference on Intelligent Computing and Control Systems (ICICCS)*, 607-612.
6. Zhang, L., Li, L., & Du, J. (2020). Research on hybrid authentication system based on RFID and fingerprint recognition. *2020 2nd International Conference on Big Data Engineering and Technology (BDET)*, 137-140.
7. Chen, Y., Zhang, L., & Wang, Q. (2021). Design of a door lock system based on RFID and fingerprint recognition. *2021 2nd Asia Conference on Robotics, Automation and Mechatronics (ACRAM)*, 433-437.
8. Kim, S. W., Choi, H. L., & Kim, H. S. (2018). Development of a multi-modal biometric authentication system for door lock security. *2018 IEEE International Conference on Consumer Electronics-Asia (ICCE-Asia)*, 1-5.
9. Sharma, A., & Rani, R. (2019). RFID-based security and access control system using Arduino. *2019 3rd International Conference on Computing Methodologies and Communication (ICCMC)*, 1482-1487.
10. Gupta, A., Kumar, S., & Jain, A. (2021). Development of a smart door lock system using Arduino. *2021 IEEE 11th International Conference on Advanced Computing (IACC)*, 1-5.