

Implementation and Controlling of Power Theft using GSM Technology

Dr. Vispute Pankaj G.

Dept. Electronics And Telecommunications
Shatabdi Institute Of Enginnering &
Research, Nashik, Maharashtra, India

Dr. Sapana P. Sonar

Dept. Electrical Engineering
Shatabdi Institute Of Enginnering &
Research, Nashik, Maharashtra, India.

Abstract

This paper presents a detection of power theft in every houses and in industry for different methods of theft. Electrical energy is very important for everyday life and spine for the industry. Electricity is indiscipline to our daily life with increasing need of electricity the power theft is also increasing, power theft is a problem that continues to plague power sector across whole country the objective of this project is to design such a system which will try to reduce the illegal use of electricity and also reduce the chances of theft. This project will automatically collect the reading and also detect the theft This model reduces manual manipulation work and try to achieves theft control. A definitive objective of our task is to screen control drawn before the vitality meter which will be consider as a power burglary. On the off chance that the power burglary is distinguished then the association will gets separated naturally to the shopper and the SMS will send to the control room then the punishment will be taken against the unlawful purchasers.

Introduction

The most common problem in our country is electrical power theft. The population in our country is very high and the power theft is also increasing day by day. Every year we are facing number of domestic electricity thefts and power thefts in industrial supply, that results in loss of distributed power to the supplier and because of which we are facing the continuous problems like power cut in urban and rural areas. This project helps to avoid the problems in satisfying the need of electricity for whole country. There are numerous ways using which electricity theft can be done, so it is difficult to track how a theft has occurred, and this issue has to be solved as early as possible. Our proposed abstract is an electricity theft detection system which is used to detect the theft automatically that is made by the most irregular way of bypassing the transmission line with a piece a wire. In this system a current sensor is used which is used to sense the total amount of current consumed by the load. If any tapping has done in the line during transmission, more current will be drawn by the sensor, which indicates that electricity theft has been occurred. The theft information is then quickly accessed by the Arduino mega and a SMS will be send to the mobile through the GSM technology.

In INDIA, almost all over the states the power supply companies used poles to supply electricity. This provide advantage that people stay away from transmission cables. But due to poverty, most of the people try to theft the electricity from the transmission cable. This makes a major loss to the companies. To overcome this loss the companies increase the rates this indirectly affects common peoples. So to overcome this illegal action we have developed the system were we are using Arduino Atmega328 and current sensors and GSM module attached to every pole. The current sensor keeps the track of amount of current pass through it. When this supply reaches to other end of the pole than the current sensor available at pole 2 will measure the current receive and gives the reading to the Arduino Atmega328. Then the Arduino compares the current readings to the previous readings and if the supply is not approximately equal than the Atmega328 trigger the GSM module. Then the GSM module will send the SMS to the distributor thatthe amount of current received is not approximately equal and there is some illegal action occurred in the section from pole I to pole 2. This will help the distributor to overcome the losses and where the losses will be take place and the theft of the electricity.

Literature Review

The existing wireless communication system of energy meter has been done using ZIGBEE relay control and GPRS. This method is mainly used to secure the communication channel and ZIGBEE for the transmission of data in a serial process. The drawback of this system is that the meter readings can be collected only by going to the particular

range of area and cut power supply manually if needed.

In the system proposed by R GiridharBalakrishna, P Yogananda Reddy. MLN Vital the IOT technology is used to detect the theft of electricity. The power transferred and the power consumed is measured and the difference is used to detect the theft of power.

In the system proposed by AnshuSinghal. AnupriyaTomar, NehaKumari. S HenaKauser, Mrs. Savitha. S.C. the theft of power and location is also determined in this system. This system uses IR sensors and camera to detect the theft of power. The theft is detected when the IR sensor is tripped when a person approaches the electric pole. The camera can take pictures of the thief when the theft is detected.

In the system proposed by N Kunan, Poornima BK real time power transfer data is stored in an online database which can be viewed by logging in the website. The detection of power theft is by finding the difference of power transferred and power consumed. CSEIT 184504 | Published - 14 April 2018 | March-April-2018] (4) 5:35-39] International Conference on New Horizons in Science Engineering Technology (NHSET- 2018) International Journal of Scientific Research in Computer Science, Engineering and Information Technology © 2018 IJSRCSEIT | Volume 4 | Issue 5 ISSN: 2456-3307 36 B.

System Block Diagram

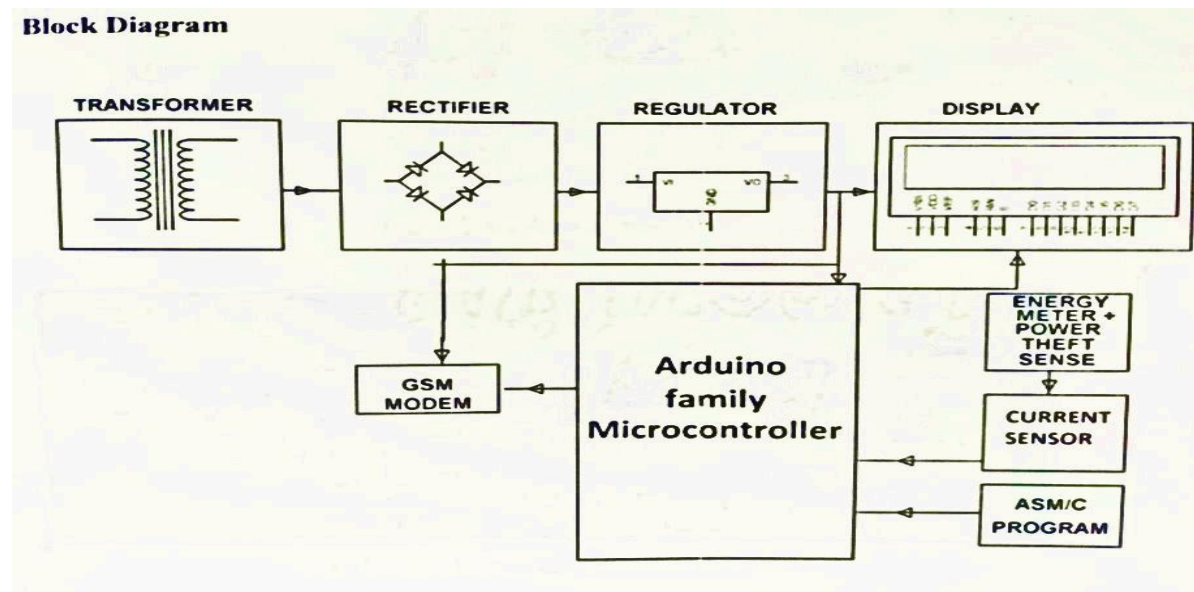

Figure System Block Diagram

At that point the vitality meter will be associated with Opto coupler, in this if robbery happens the miniaturized scale controller will send an insinuation to the MAX232 after that SMS will be sent to client. In this show demonstrates the status of the miniaturized scale controller. In the small scale controller inserted c program has been coded. In the vitality meter one load will be associated and another heap will be associated specifically before the vitality meter. In this opto coupler is the most critical part it has a transistor and diode. In this lone both the CT transformers are associated and the heap can be estimated based on the two burdens

Result



Figure Status When It Is Off



Figure Status When It Is On

Conclusion

A GSM Electricity Theft Detection and monitoring system has been designed and developed with proper integration of both the hardware and the software. Without any human interface this system provides an effective and easy way to detect electrical theft. The use of GSM helps in achieving the numerous advantages of wireless network systems. Power theft is actually bypassing the energy meter but in our project we have indicated the theft by increasing the load and this method is cost efficient

References

- [1] G.L. Prashanthi, K.V. Prasad 2016, Wireless power meter monitoring with power theft detection and intimation system using GSM. International journal of engineering science and computing, Volume9, pp. 330-348.
- [2] J.L. Parra and E.A.S. Calderon 2013, Use of shunts detecting equipment for the identification of illegal power outlets, International Journal of Innovative research in science, engineering and technology. pp. 1-4.
- [3] S.K.A. Zaidi, H. Mansoor. S.R. Ashraf, and A. Hassan 2014. Design and implementation of low cost electronic prepaid energy meter. IOSR Journal of Electronics and Communication Engineering, Volume: 02. pp. 548-552.
- [4] PradeepMittal 2015, Wireless Electricity billing system. International ResearchJournal of Engineering and Technology (IRJET) Volume: 02, pp.21-34.
- [5] M.Jamil, F.Munir, A.A.Khan, and A.Mirza 2014. Telemetry & billing system for spatially distributed electrical power clients, Electrical power system research pp. 35-40.
- [6] IOT based Power Theft Detection. R GiridharBalakrishna, P Yogananda Reddy, M.L N Vital.. International Journal of Innovations in Engineering and Technology (UIET) ISSN: 2319-105, Volume 8, Issue 3. June 2017
- [7] A Survey of IOT For Power Theft Detection. Fault Identification And Location Tracking. AnshuSinghal, AnupriyaTomar, NehaKumari, S HenaKauser, Mrs. Savitha S.C. International Journal of Science. Engineering and Technology Research (USETR) Volume 5, Issue 5, May 2016 1.S. Jacobs and C.P. Bean, "Fine particles, thin films and exchange anisotropy." in Magnetism, vol. III, G.T. Rado and H. Suhl, Eds. New York: Academic, 1963, pp. 271-350.
- [8] IOT Based Power Theft Detection and Monitoring System. N Kunan, Poornima BK. UIREEICE. Vol. 5, Issue 5, May 2017